

**DESIGN AND MODEL OF AN INDUCTIVE WIRELESS POWER TRANSFER
SYSTEM FOR ELECTRIC VEHICLES**

Vekil SARI

Sivas Cumhuriyet University

ORCID NO: 0000-0001-5963-0179

ABSTRACT

Wireless power transfer (WPT) systems has become very important in recent years. WPT is used in many areas. In this study, an inductive wireless power transfer (IWPT) system was designed for electric vehicles. The shape of the primary and secondary coils is circular and their radius is 25 cm. The operating frequency of the system is 20 KHz and the applied voltage is 100 volts. The effect of the distance between the primary and secondary coils on the efficiency of the system was investigated by generating a 3D Maxwell model of the system. The distance between the primary and secondary coils was modified as 10, 15, 20 and 25 cm and the coupling coefficient, mutual inductance, input power, output power and efficiency of the system were investigated in each case. As a result, it was observed that the coupling coefficient, the common inductance, and the efficiency of the system are inversely proportional with the distance between the coils. When the distance between the coils was 10 cm, the efficiency of the system was 84.21%. As the distance between the coils increases, the system efficiency decreases and when the distance between the coils is 25 cm, the system efficiency becomes 71.07%.

Keywords: Wireless power transfer, contactless power transfer, inductive power transfer.

1. Introduction

Wireless power transfer (WPT) systems have advantages such as simplifying the charging process by eliminating cables, not being affected by weather conditions and no arcing [1]. Therefore, it has become very important in recent years. WPT is used in many areas. One of them is the charging of electric vehicles. WPT systems are divided into inductive and capacitive. Inductive coupling has coils and a magnetic field is used for the transfer of energy. In capacitive coupling, there are conductive plates and electric field is used for the transfer of energy [2].

In IWPT systems, since the system is inductive, the power factor is low, and compensation is done to increase the power factor. Therefore, capacitors are connected in series or parallel to the primary and secondary coils. According to the serial and parallel connection status of the

capacitors, there are 4 different connection types as serial serial (SS), serial parallel (SP), parallel serial (PS) and parallel parallel (PP). Figure 1 shows the connection types. SS connection has some advantages over other connection types. These advantages are described in [3].

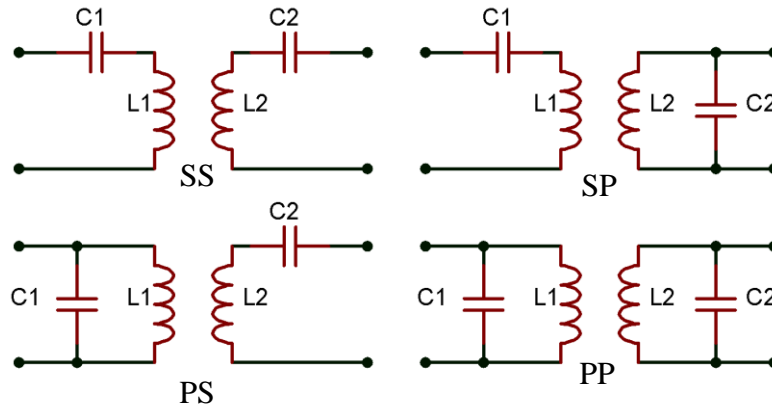

Figure 1. Capacitor connection types in IWPT systems.

The relationship between the resonant frequency, and the primary/secondary coils and capacitors in IWPT systems is given in Equation 1 [4]. Here, L_1 is the inductance of the primary coil, L_2 is the inductance of the secondary coil, C_1 is the capacitance of the primary capacitor, and the C_2 is the capacitance of the secondary capacitor. In systems with Serial-Serial connection, primary quality factor is calculated by Equation 2 and secondary quality factor is calculated by Equation 3 [5].

$$w_0 = \frac{1}{\sqrt{L_1 C_1}} = \frac{1}{\sqrt{L_2 C_2}} \quad (1)$$

$$Q_1 = \frac{R_L L_1}{w_0 M^2} \quad (2)$$

$$Q_2 = \frac{w_0 L_2}{R_L} \quad (3)$$

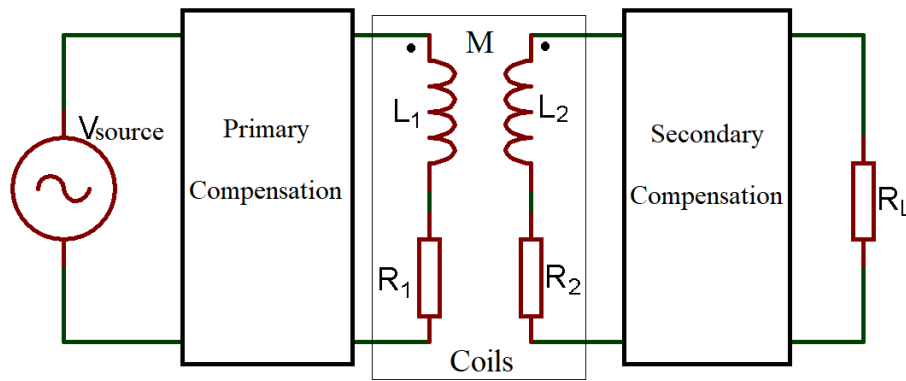

Figure 2. General schematic of an IWPT system [6].

The IWPT system consists of primary and secondary parts that are not in contact with each other, as shown in Figure 2. The primary part consists of a high frequency power supply, a capacitor C_1 connected in series or parallel for primary compensation, and a primary coil. Secondary part consists of the secondary coil and the secondary capacitor C_2 connected in series or parallel for secondary compensation and load.

In a previous study [7], the inductively coupled power transfer system was investigated and to validate the theoretical results, a 2-KW SS compensated prototype with a 15-cm air gap between coils, was implemented. The shape of the coils in this prototype is rectangular and the operating frequency is 20 KHz. The number of turns for the primary coil is 27, the number of turns for the secondary coil is 7. The theoretical efficiency of the system is 95% and the experimental efficiency is 82%.

In another study [8], the compensation topologies of the inductively coupled power transfer system were investigated and a novel compensation topology was proposed. The proposed compensation topology is the SPS topology, which is a combination of SS and PS topologies. Then, two prototypes with SS and SPS compensation topologies were implemented. The dimensions of the primary and secondary coils which were wound using Litz wire, are different in order to consider misalignment in only one direction. The primary coil is rectangular, the secondary coil is square and the distance between them is 15 cm.

In another study [9], models of circular and DD-coupled inductive power transfer systems were generated with finite element analysis software. The power of the system is 2 KW and the distance between the coils is 20 cm. As a result, it was concluded that the DD-coupled system is more efficient.

2. Model of IWPT System

In this study, the IWPT system was designed, and then a 3D Maxwell model of this system was generated. The magnetic field representation of the 3D Maxwell model of the proposed IWPT system is shown in Figure 3.

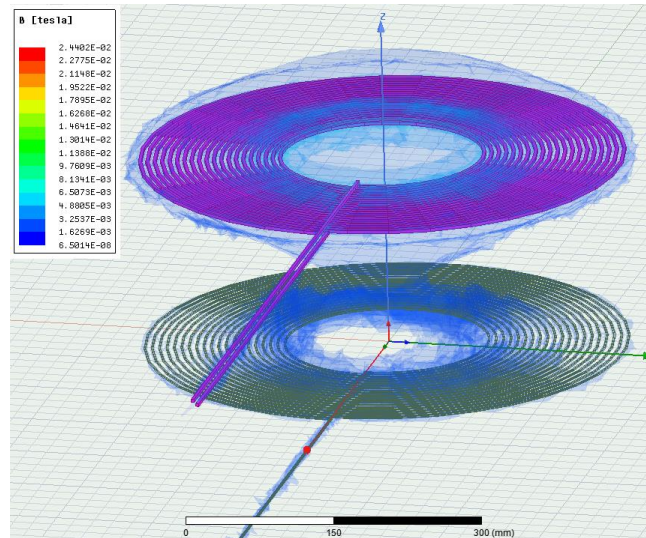

Figure 3. Magnetic field representation of the IWPT system.

The coupling coefficient (k), self-inductance of the primary coil (L_1), self-inductance of the secondary coil (L_2) and mutual-inductance (M) when the distance between the primary and secondary coils is 10, 15, 20 and 25 cm were obtained from the model. C_1 and C_2 values from Equation 1, Q_1 values from Equation 2 and Q_2 values from Equation 3 were calculated. These values are given in Table 1.

Table 1. Design parameters of the IWPT system.

Distance	10 cm	15 cm	20 cm	25 cm
k	0,36	0,23	0,16	0,11
L_1 (uH)	162,08	162,04	161,95	161,69
L_2 (uH)	155,8	155,76	155,74	155,56
M (uH)	58,03	38,02	25,66	17,76
C_1 (nF)	391,29	391,29	391,41	392,04
C_2 (nF)	406,86	407,12	407,12	407,65
Q_1	1,917	4,466	9,791	20,406
Q_2	3,913	3,911	3,911	3,906

Figure 4 shows the change of the coupling coefficient vs the distance between the coils. When this graph is analyzed, we can see that the coupling coefficient decreases as the distance between the coils increases and the coupling coefficient is 0.36 when the distance between the coils is 10 cm. When the distance between the coils is 25 cm, the coupling coefficient becomes 0.11. As shown in Figure 4, the coupling coefficient is inversely proportional to the distance between the coils.

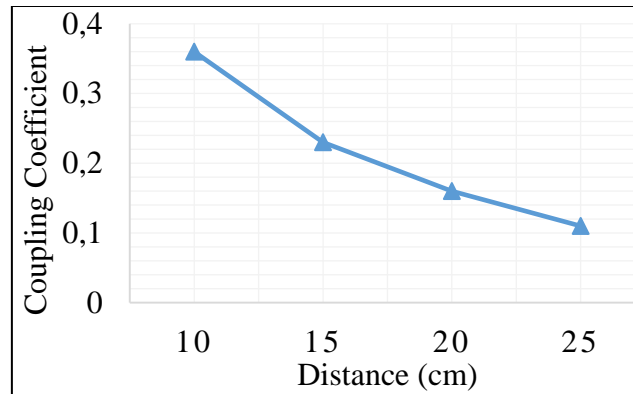

Figure 4. Coupling coefficient vs distance between the coils.

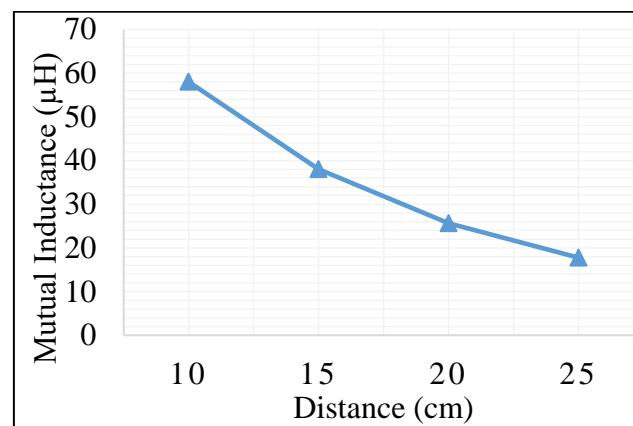

Figure 5. Mutual inductance vs distance between the coils.

A coupling coefficient of zero means that there is no coupling, that is, the power transfer is zero. Conversely, the larger the coupling coefficient, the more power is transferred and the efficiency of the system increases. Therefore, it is desirable to have a large coupling coefficient in the design of IWPT systems. The coupling coefficient can be calculated by Equation 4 [10].

$$k = \frac{M}{\sqrt{L_1 L_2}} \quad (4)$$

Figure 5 shows the change of the mutual inductance vs the distance between the coils. As shown in Figure 5, the common inductance decreases as the distance between the coils increases.

3. Simplorer Circuit

After the generation of the 3D Maxwell model of the IWPT system, the Simplorer circuit was built for efficiency analysis. Figure 6 shows the Simplorer circuit of the IWPT system. Here, the load resistance R_L is 5 ohms. As shown in Figure 7, V_{source} voltage is a bipolar square wave with an RMS value of 100 volts. As shown in Figure 8, the I_{source} current is a sinusoidal current with a maximum value of 12.2 amperes and an RMS value of 8.55 amperes.

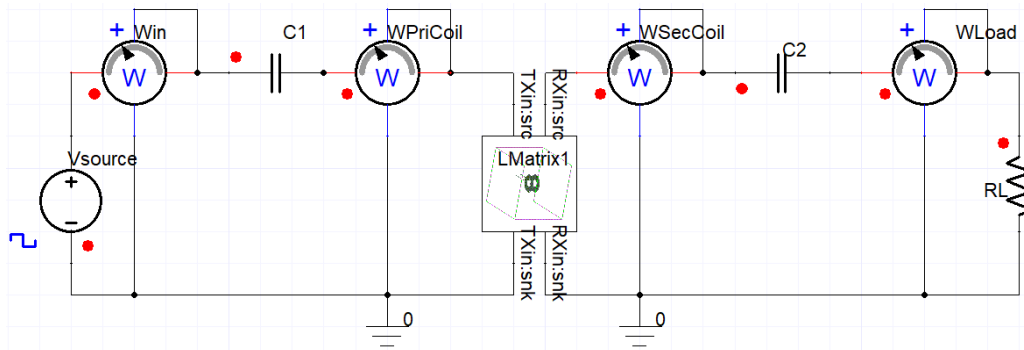

Figure 6. Simplorer circuit of IWPT system.

Figure 9 shows the load current I_L . As shown in Figure 9, the maximum value of the load current is 16.51 amperes, and the RMS value is 12.01 amperes. Figure 10 shows the load voltage V_L . As shown in Figure 10, the load voltage is a sinusoidal voltage with a maximum value of 82.56 volts and an RMS of 60 volts.

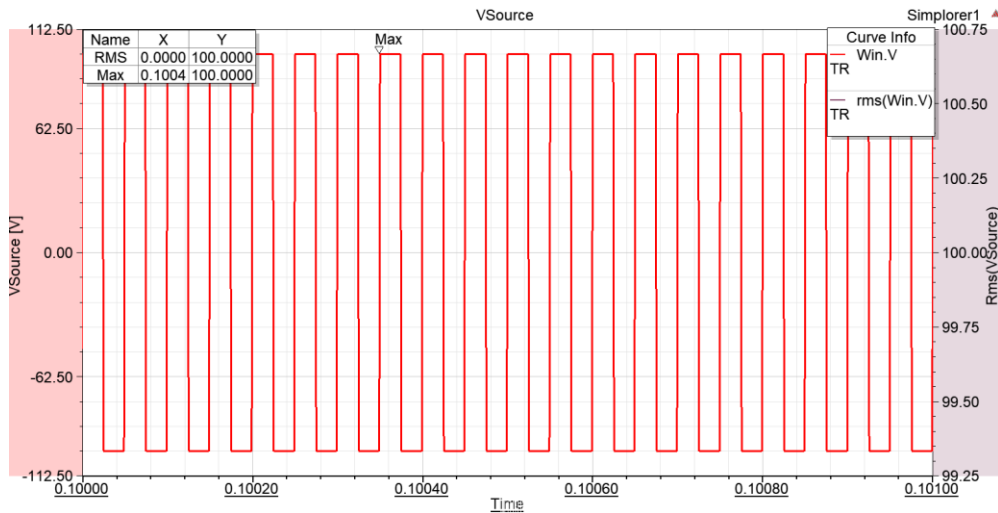

Figure 7. V_{source} voltage.

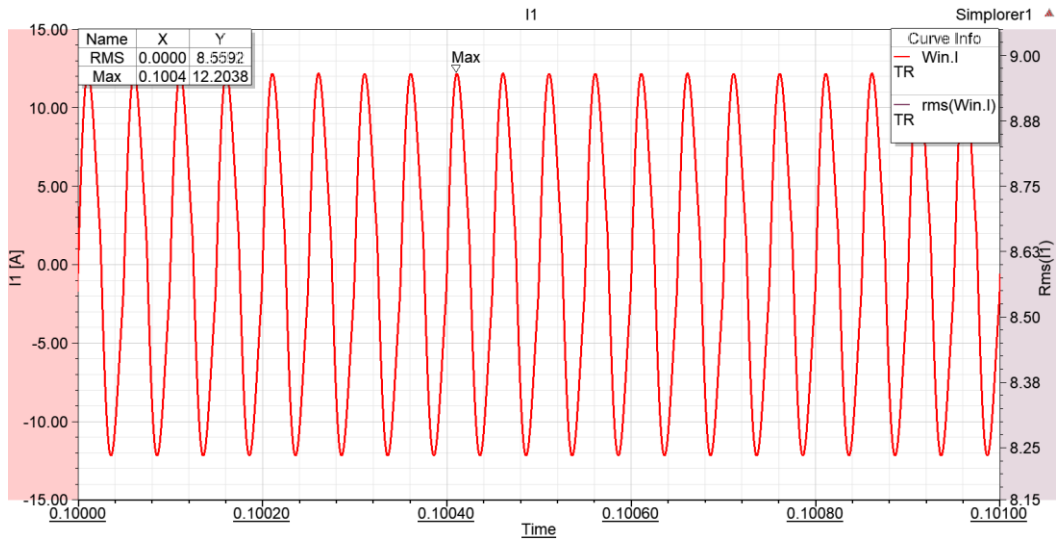

Figure 8. I_{source} current.

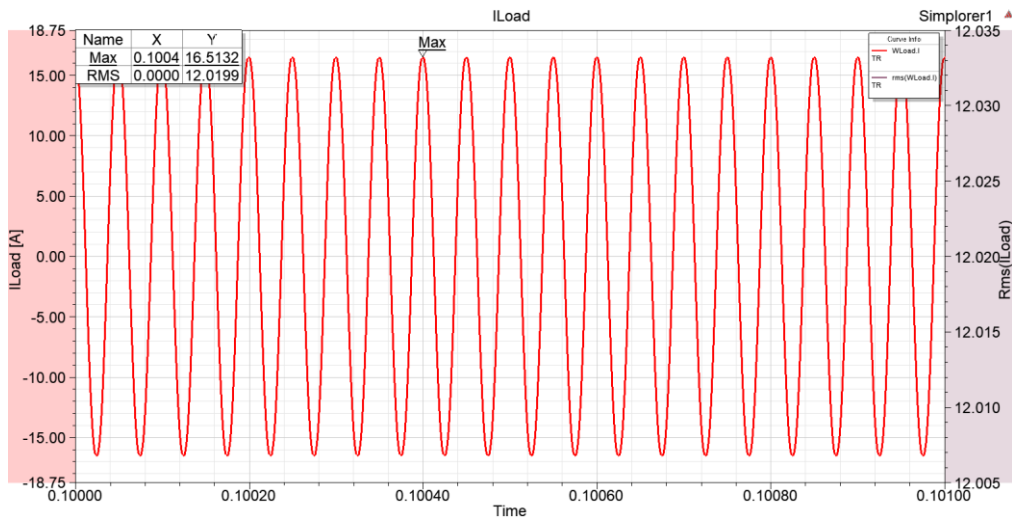

Figure 9. I_L current.

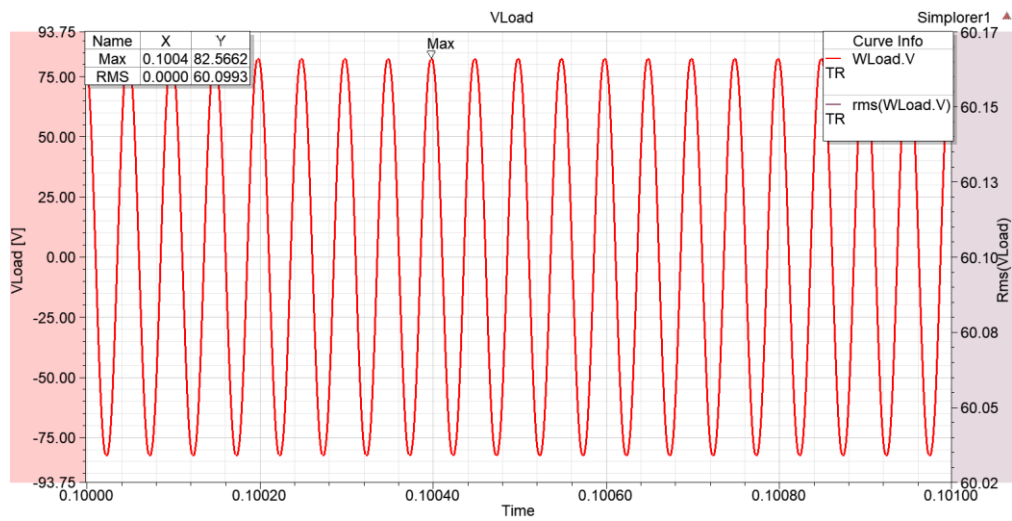

Figure 10. V_L voltage.

4. Model results

The distance between the coils in the generated model was modified as 10, 15, 20 and 25 cm and the source current (I_{source}), load current (I_L), load voltage (V_L), input power (P_{in}) and output power (P_L) were obtained in each case. The obtained values are given in Table 2.

Table 2. Model results.

Distance	10 cm	15 cm	20 cm	25 cm
V_{source} (V)	100 V	100 V	100 V	100 V
I_{source} (A)	8,55	19,4	40,4	76,57
P_{in} (W)	855	1940	4040	7657
V_L (V)	60	89,45	125,79	164,96
I_L (A)	12	17,89	25,15	32,99
P_L (W)	720	1600	3163	5442
Efficiency	84,21	82,48	78,3	71,07

In Figure 11, the change of the input power vs the distance between the coils is shown. In Figure 12, the change of the output power vs the distance between the coils is shown. These graphs demonstrate that the input power and the output power increase as the distance between the coils increases. Figure 13 shows the change of the system efficiency vs the distance between the coils. As shown in Figure 13, the efficiency of the system decreases as the distance between the coils increases, the efficiency of the system is 84.21% when the distance between the coils is 10 cm, and the efficiency of the system is 71.07% when the distance between the coils is 25 cm.

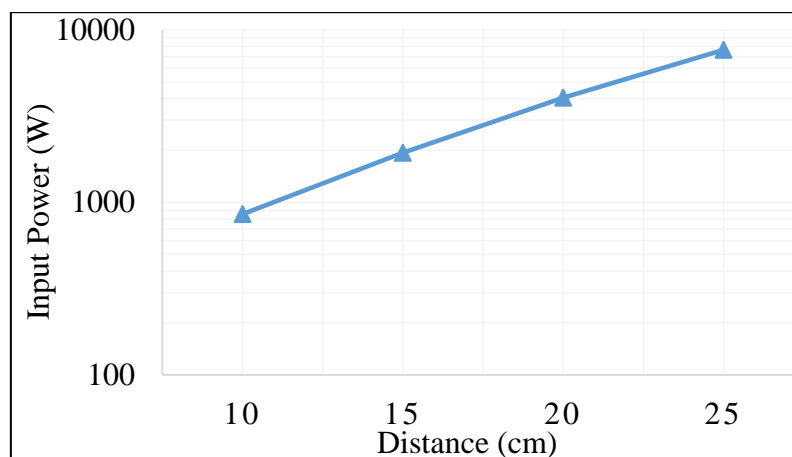

Figure 11. The input power vs the distance between the coils.

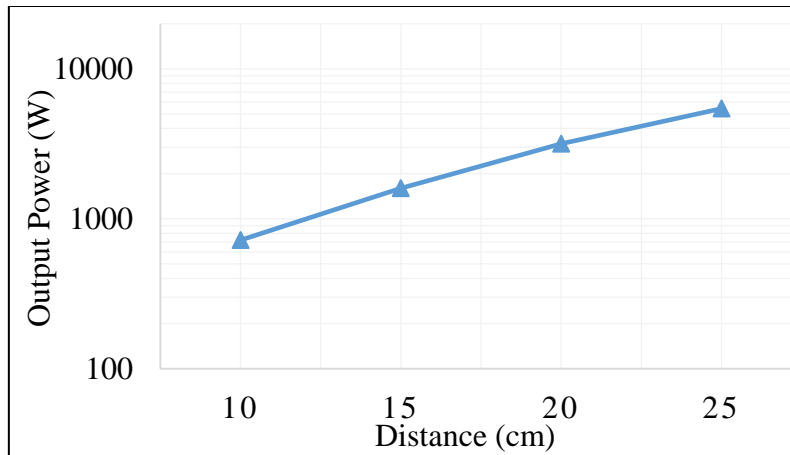

Figure 12. The output power vs the distance between the coils.

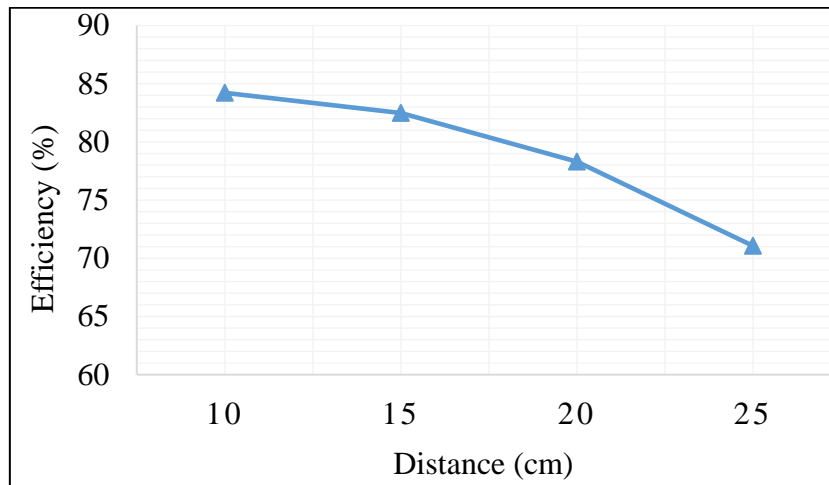

Figure 13. The system efficiency vs the distance between the coils.

5. Conclusions

In this study, an inductive wireless power transfer (IWPT) system that can be used in electric vehicles is designed. In the designed system, the shape of the primary and secondary coils is circular, and the radius is 25 cm. Initially, the 3D Maxwell model of the designed system was generated and then the Simplorer circuit was built. The operating frequency of the system is 20 KHz and the applied voltage is 100 volts. The distance between the coils in the generated model was taken as 10, 15, 20 and 25 cm and each case was investigated correspondingly. As a result of the investigations, it was shown that the coupling coefficient, mutual inductance, and efficiency of the system decreased as the distance between the coils increased. In future studies, it can be investigated whether systems with different coil shapes (rectangular, square, hexagonal, DDQ) will be more efficient or not. The effect of changes in the current system parameters (input voltage, number of turns, resonance frequency, load resistance) on system efficiency can also be investigated. In addition, it can be investigated how much the efficiency

**4TH INTERNATIONAL LATIN AMERICAN
CONGRESS ON NATURAL AND APPLIED SCIENCES**

of the system will change if the outer surfaces of the primary and secondary coils are coated with ferrite strip and aluminum plate.

References

- [1] Green, A. W., & Boys, J. T. (1994). 10 kHz inductively coupled power transfer-concept and control. 1994 Fifth International Conference on Power Electronics and Variable-Speed Drives. 26-28 October 1994. London, UK. doi: 10.1049/cp:19941049
- [2] Afridi K. (2018). Wireless charging of electric vehicles. National Academy of Engineering. In *Frontiers of Engineering: Reports on Leading-Edge Engineering from the 2017 Symposium*. Washington, DC: The National Academies Press. September 25-27. doi: <https://doi.org/10.17226/24906>.
- [3] Garcia, X. D. T., Vazquez, J., & Roncero-Sánchez, P. (2015). Design, implementation issues and performance of an inductive power transfer system for electric vehicle chargers with series-series compensation. *IET Power Electronics*, 8(10), 1920-1930.
- [4] Minnaert, B., & Stevens, N. (2018). Maximizing the power transfer for a mixed inductive and capacitive wireless power transfer system. In *2018 IEEE Wireless Power Transfer Conference (WPTC)*. Canada. doi: 10.1109/WPT.2018.8639265
- [5] Wang, C. S., Covic, G. A., & Stielau, O. H. (2001). General stability criterions for zero phase angle controlled loosely coupled inductive power transfer systems. In *IECON'01. 27th Annual Conference of the IEEE Industrial Electronics Society*. USA. 1049-1054. DOI: 10.1109/IECON.2001.975925
- [6] Trivino-Cabrera, A., Gonzalez-Gonzalez, J. M., & Aguado, J. A. (2020). *Wireless power transfer for electric vehicles: foundations and design approach*, Springer.
- [7] Sallan, J., Villa, J. L., Llombart, A., & Sanz, J. F. (2009). Optimal design of ICPT systems applied to electric vehicle battery charge. *IEEE Transactions on Industrial Electronics*, 56(6), 2140-2149. doi: 10.1109/TIE.2009.2015359
- [8] Villa, J. L., Sallan, J., Osorio, J. F. S., & Llombart, A. (2011). High-misalignment tolerant compensation topology for ICPT systems. *IEEE Transactions on Industrial Electronics*, 59(2), 945-951. doi: 10.1109/TIE.2011.2161055
- [9] Budhia, M., Boys, J. T., Covic, G. A., & Huang, C. Y. (2013). Development of a single-sided flux magnetic coupler for electric vehicle IPT charging systems. *IEEE Transactions on Industrial Electronics*, 60(1), 318-328. doi: 10.1109/TIE.2011.2179274
- [10] Zheng, C., Ma, H., Lai, J. S., & Zhang, L. (2015). Design considerations to reduce gap variation and misalignment effects for the inductive power transfer system. *IEEE Transactions on Power Electronics*, 30(11), 6108-6119.